



DILLIMAX

Welding

High strength DILLIMAX is highly suitable for processing due to its exceptional homogeneity as well as its cleanness. Increasing yield strength and plate thickness requires increased amounts of alloy components and careful treatment of the plate, especially in the case of heat input during welding. DILLIMAX is suitable for welding with all common welding methods.



The information on DILLIMAX welding has been developed in accordance with Dillinger's best knowledge and experience. It is intended to support the manufacturers in developing their own processing procedure for DILLIMAX.

Optimum mechanical properties of weld seams as well as welds without defects are achieved by observing the entire process chain and creating suitable welding conditions.

General rules of welding technology as well as the processing recommendations according to EN 1011 must be observed. The necessary safety measures must be taken during processing.

Table 1 Welding method

Method	Acronym	Energy source	Thermal efficiency factor k	Applicability
Submerged arc welding	SAW	Electric arc	1	up to DILLIMAX 690
Manual arc welding	MMA	Electric arc	0.8	up to DILLIMAX 890
Gas-shielded arc welding, such as Metal Active Gas	GSAW	Electric arc	0.8	up to DILLIMAX 1100

Overview of welding parameters

Heat input (effective)

Voltage [V]:	U
Current [A]:	I
Welding speed [mm/min]:	v
Power P [Watt]: Voltage · Current	(U · I)
Heat input E [kJ/mm]: Power / speed (P / v):	(U · I) / v · (60/1000)

Efficiency-> Radiation
Effective heat input Q:

$$E \cdot k \quad (k = \text{Thermal efficiency factor, see EN 1011})$$

Two- and three-dimensional heat flow

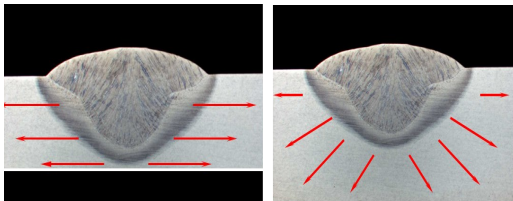

2 D at t = 20 mm

3 D at t = 35 mm

The heat energy applied during the welding process flows off perpendicularly or parallel to the plate surface. Especially with plate thicknesses < 20 mm, the heat input must be limited to prevent slow cooling of the weld. The transition from two- to three-dimensional heat flow is influenced by the temperature and heat input for large plate thicknesses.

Carbon equivalents

$$CEV = C + Mn/6 + (Cr+Mo+V)/5 + (Cu+Ni)/15$$

$$CET = C + (Mn+Mo)/10 + (Cr+Cu)/20 + Ni/40$$

Preheating temperature T_0 according to EN 1011-2 method B¹⁾ to avoid hydrogen cracks

$$T_0 = 700 CET + 160 \tanh(t/35) + 62 HD \exp 0.35 + (53 CET - 32) Q - 330$$

Depending on:

Carbon equivalent CET; plate thickness t; hydrogen content HD; effective heat input Q

$t_{8/5}$ -time

The cooling time in which the temperature of a bead drops from 800 °C to 500 °C.

The $t_{8/5}$ time is calculated based on the specifications in EN 1011 method B.

Recommendations for calculation of the welding parameters mentioned and preheating temperature can be found in [Dillinger E-Service](#) on the basis of the actual analysis and further data.

1) Further details can be found in EN 1011-2.

Weld seam including weld seam preparation

The weld preparation can have a significant effect on the quality of the weld achieved.



Edge-milled plates

The weld edge can be prepared by machining or by thermal cutting. At the beginning of welding, the edge must be bright, dry and free of flame cutting slag, rust, scale, paint and any other impurities.

Any protective primer previously applied to the plate must be removed (Note: some primers can be welded over - see Dillinger's brochure "Raincoat included").

Weld seam

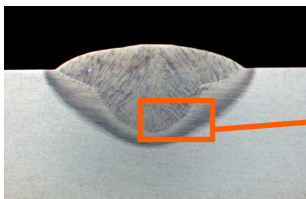

Tack weld

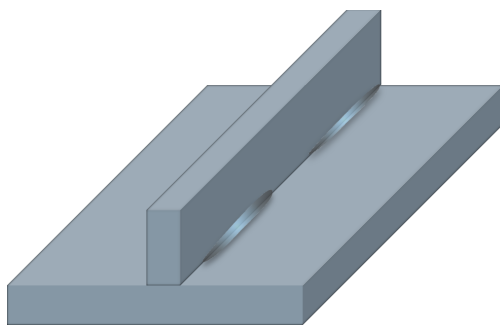

The minimum length of the welding bead should be 50 mm.

For plate thicknesses:

< 12 mm, at least 4 times the thicker part.

> 50 mm (or $R_e > 500$ MPa), an increase in thickness and length of the tack weld should be considered.

Tack welds should not start directly at the outer edge.

Tack welds can also be made using soft filler metals.

Butt joint

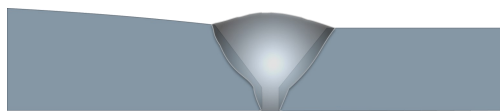
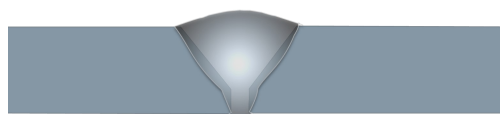

Butt joints of parts with unequal cross sections positioned in one direction can be aligned with an inclination of less than 1:4.

Double fillet weld

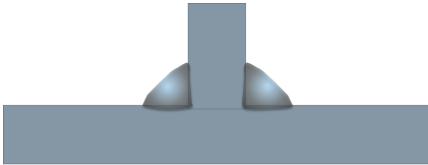

The weld seam differs from the standard technical heat treatment due to its

- ◆ high heating rate
- ◆ high maximum temperature
- ◆ short dwell time
- ◆ high cooling rate

Lamellar tearing

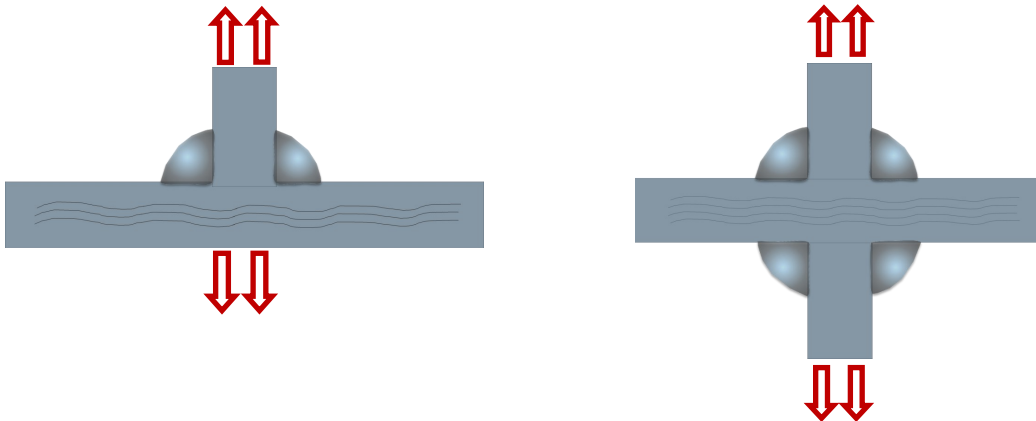

If high stresses are expected due to tensile or bending forces in the thickness direction, e.g. in T-joints, constructive countermeasures must be taken to avoid lamellar tearing. The compliance with certain minimum requirements of the reduction of area in the through thickness direction is determined according to EN 10164 and must be agreed when placing an order.

DILLIMAX has very good characteristics to withstand these stresses due to its low content of accompanying elements and high degree of thickness deformation. If so-called Z-grades with improved properties in the thickness direction are required, please contact Dillinger before ordering.

Weld seam with different heat input

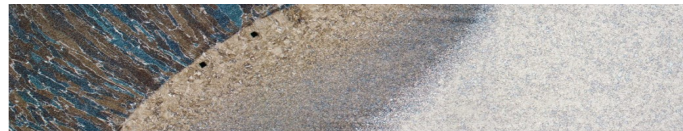
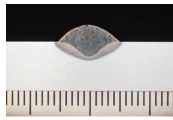

GMAW - 0.65 kJ/mm

$t_{8/5}$ 4 s

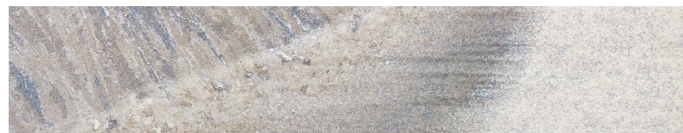
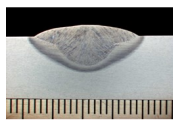

MMA - 1.8 kJ/mm

$t_{8/5}$ 12 s

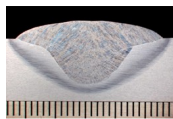

MMA - 3.5 kJ/mm

$t_{8/5}$ 38 s

Heat input per unit length of weld and heat cycles during welding

The cooling time $t_{8/5}$ is generally used to describe the heat cycles occurring during welding.

To prevent excessive impairment of the properties of the steel due to the thermal load during welding, upper limits must be set for the cooling time and thus for the heat input per unit length of weld. The following graphic shows what effect an increasing $t_{8/5}$ time has on the yield strength of the weld metal. Furthermore, a lower limit for the $t_{8/5}$ time is also necessary: Excessive hardening of the heat-affected zone can be caused by cooling down too rapidly. Moreover, hydrogen-effusion, which promotes hydrogen-induced cracking in the weld metal and heat affected zone, is prevented.

Effects of the $t_{8/5}$ time on the yield strength of the weld metal of DILLIMAX 965
(10 mm plate thickness, transverse test specimens)

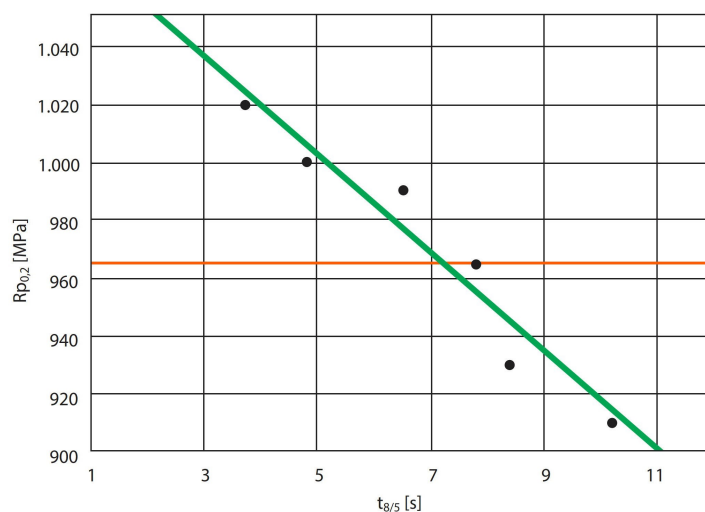

— Minimum yield strength of the base material

GMAW:

EN ISO 16834-A, Kl. G 89 5 M21 Mn4Ni2,5CrMo

The $t_{8/5}$ time is primarily determined by the heat input, the preheating, interpass temperature and the seam configuration, especially for thin plates.

As a rule of thumb, the cooling time $t_{8/5}$ can be estimated for plate thicknesses greater than 25 mm (3-dimensional) and an interpass temperature of 200 °C:

The cooling time [s] is approx. 10 times the heat input.

Example:

Plate thickness 70 mm, $T = 200$ °C and heat input of 2.5 kJ/mm results in $t_{8/5}$ of approx. 25 s.

In relation to cooling time $t_{8/5}$ at three-dimensional heat flow [kJ/mm]

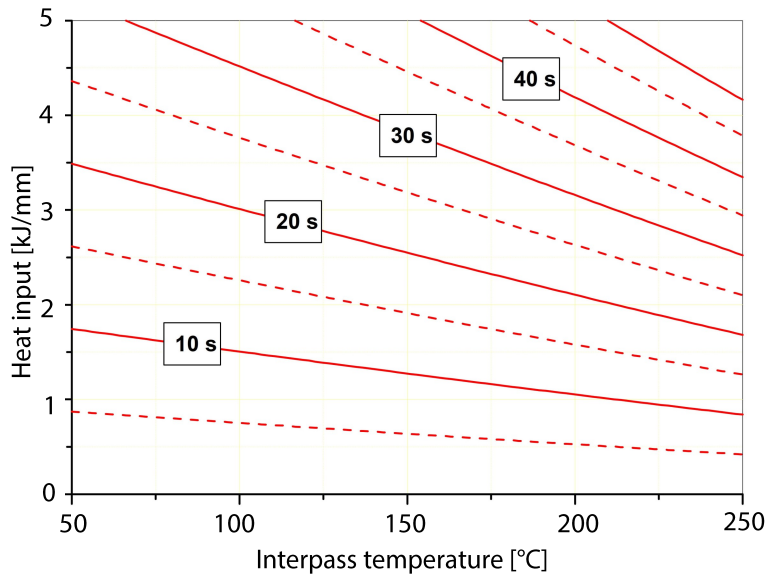

Selection of suitable $t_{8/5}$ times and the maximum permissible heat input when welding DILLIMAX

Maximum heat input for DILLIMAX 690 to reach $t_{8/5}$ time < 20 s

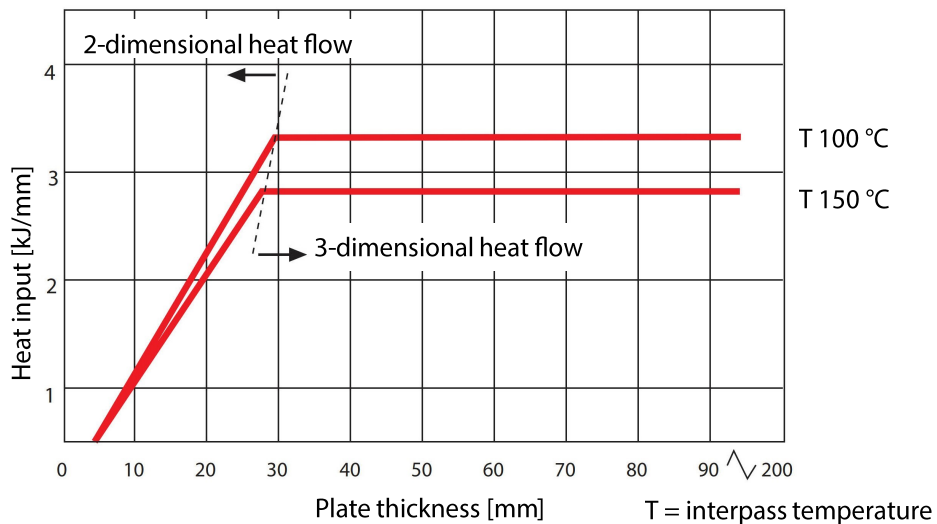

Recommended work range DILLIMAX 690

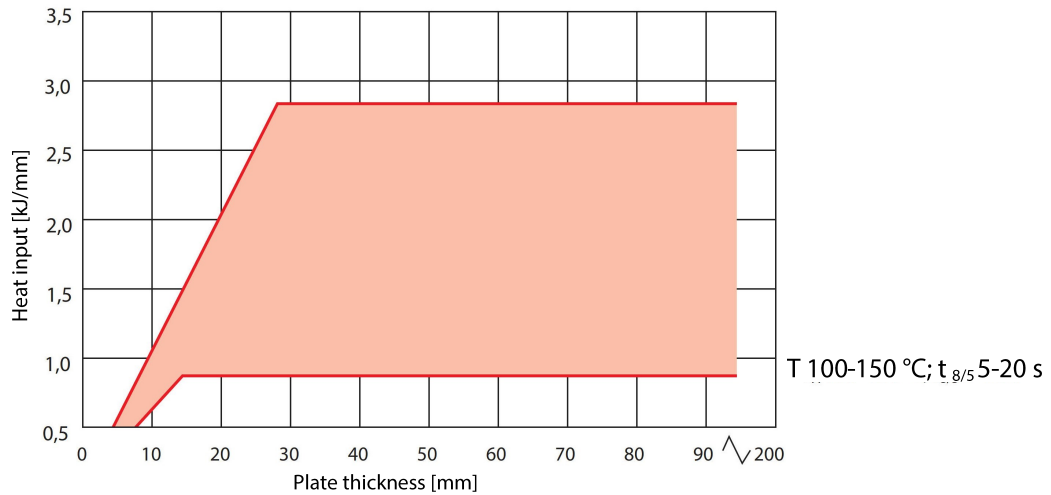

Maximum heat input of DILLIMAX 890 to reach $t_{8/5}$ time < 12 s

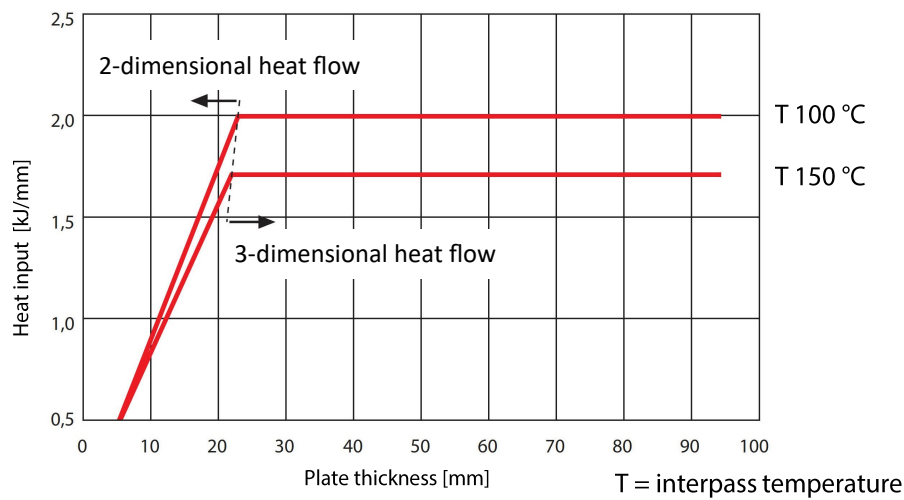

Recommended work range DILLIMAX 890

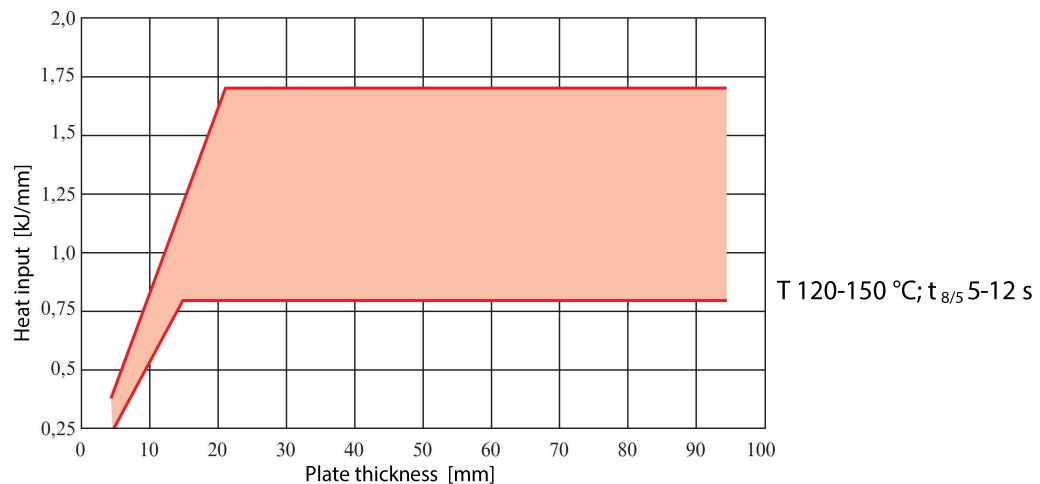

Maximum heat input of DILLIMAX 965 to reach $t_{8/5}$ time < 8 s

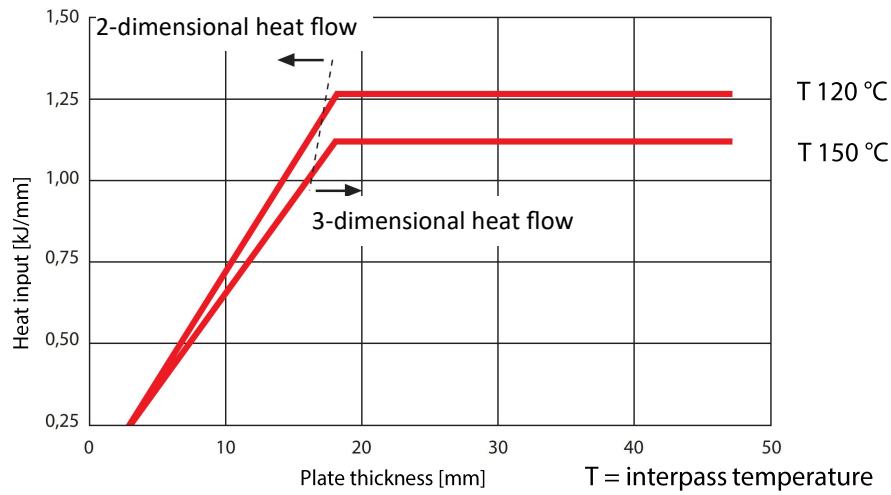

Recommended work range for DILLIMAX 965

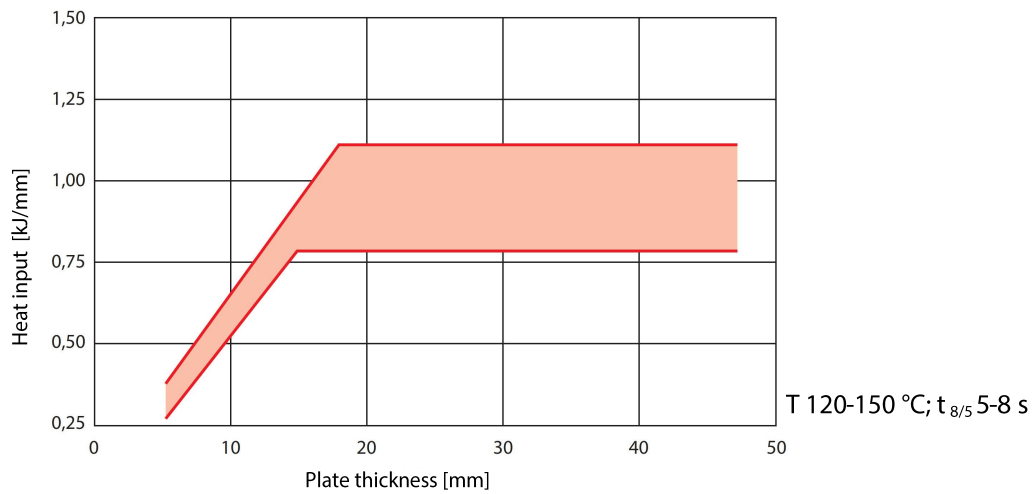

Prevention of cold cracking

As with all high strength, quenched and tempered, fine grained structural steels, DILLIMAX steels are susceptible to cracking in the weld area if the conditions are unfavourable. The hazard is that these cracks may not appear until 48 hours after welding. This must be taken into account when inspecting for cracks.

Cold cracking can be prevented by taking appropriate precautionary measures during welding:

- ◆ Minimize the hydrogen in the weld metal
- ◆ Give the hydrogen enough time to diffuse out
- ◆ Avoid any impurities and humidity in the weld seam
- ◆ Take the hardening in the heat affected zone into account (can only be partially controlled)

Typical values for hardening of the heat-affected zone in DILLIMAX with various $t_{8/5}$ times in comparison to conventional S355J2+N steel after cooling.

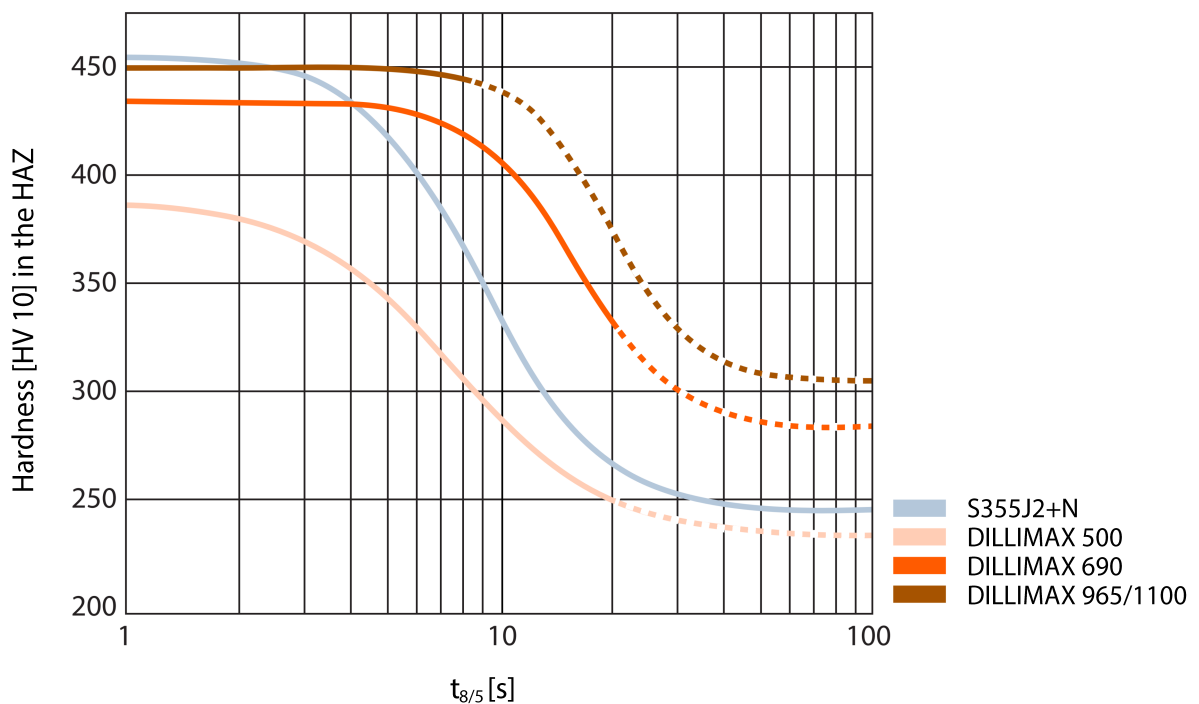

	Max. $t_{8/5}$ values for min 27 J at -40°C These values apply when using suitable filler materials of the corresponding yield strength classes
DILLIMAX 500 B/T/E	20 s
DILLIMAX 550 B/T/E	20 s
DILLIMAX 690 B/T/E	20 s
DILLIMAX 890 B/T/E	12 s
DILLIMAX 965 B/T/E	8 s
DILLIMAX 1100	2 s

Deposits of molecular hydrogen at the grain boundaries of the weld metal structure and on the fusion line are the main causes of cracking. The hydrogen enters the weld through impurities, moist weld fillers, films of moisture on the weld edges or the atmosphere surrounding the arc. It can be avoided by selecting suitable weld fillers, keeping them dry in storage and, above all, by cleaning and reheating the component to be welded.

Preheating

Preheating leads to a delay in the cooling of the component after welding, which means that the hydrogen has enough time to diffuse out. This phenomenon mainly takes place in the temperature range between 300 °C and 100 °C.

Preheating refers to both heating the weld area at the beginning of the welding process and to adhering to a certain minimum temperature throughout the welding process (interpass temperature). The preheated area should extend to at least 100 mm on either side of the seam.

The basis for calculating the preheating temperature is the actual chemical analysis shown on the corresponding certificate.

Typical values can be found under the following table:

Plate thickness	DILLIMAX 690		DILLIMAX 890		DILLIMAX 965		DILLIMAX 1100	
	CEV (CET) typical	CEV EN 10025-6	CEV (CET) typical	CEV EN 10025-6	CEV (CET) typical	CEV EN 10025-6	CEV (CET) typical	CEV EN 10025-6
t= 10	0.45 (0.34)	0.65	0.57 (0.35)	0.72	0.57 (0.35)	0.82	0.57 (0.35)	-
t= 50	0.51 (0.34)	0.65	0.54 (0.35)	0.72	0.54 (0.35)	0.82	-	-
t= 100	0.59 (0.37)	0.77	0.66 (0.39)	0.82	0.66 (0.39)	0.85	-	-
t= 150	0.63 (0.38)	0.83	-	-	-	-	-	-
t= 200	0.71 (0.41)	0.83	-	-	-	-	-	-
t= 290	0.71 (0.41)	-	-	-	-	-	-	-

$$CEV = C + Mn/6 + (Cr+Mo+V)/5 + (Cu+Ni)/15$$

$$CET = C + (Mn+Mo)/10 + (Cr+Cu)/20 + Ni/40$$

- ◆ If two plates of the same grade are welded together, the preheating temperature of the thicker plate must be maintained.
- ◆ If two plates with different chemical compositions are welded together, the minimum required preheating temperature is determined by the plate with the highest preheating temperature.
- ◆ The width of the heated zone should be at least 4 times the plate thickness. However, it should be at least 100 mm wide.

Recommended preheating temperatures during welding DILLIMAX

Recommended preheating temperatures during welding DILLIMAX in relation to plate thickness

DILLIMAX 690

Manual arc welding
(1.5 kJ/mm, HD 5 ml/100g)

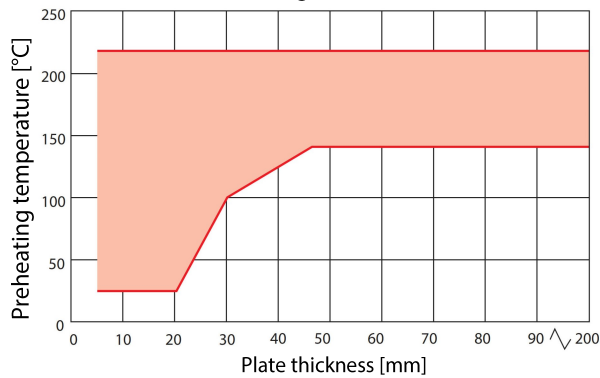

Gas shielded metal arc welding
(1.0 kJ/mm, HD 2 ml/100g)

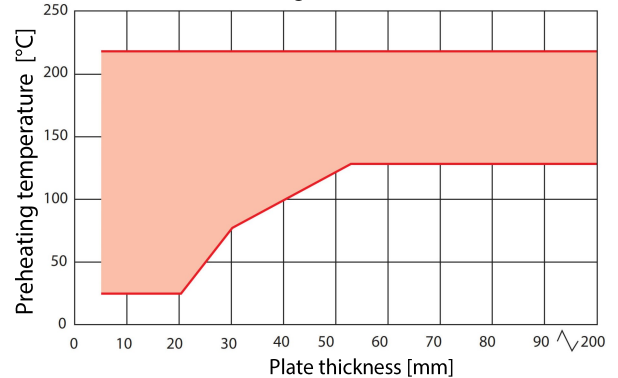

DILLIMAX 890

Gas shielded metal arc welding/ butt weld
(1.0 kJ/mm, HD 2 ml/100g)

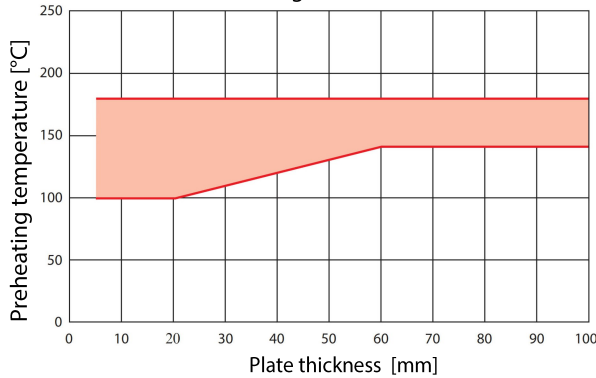

Gas shielded metal arc welding/ fillet weld
(1.5 kJ/mm, HD 2 ml/100g)

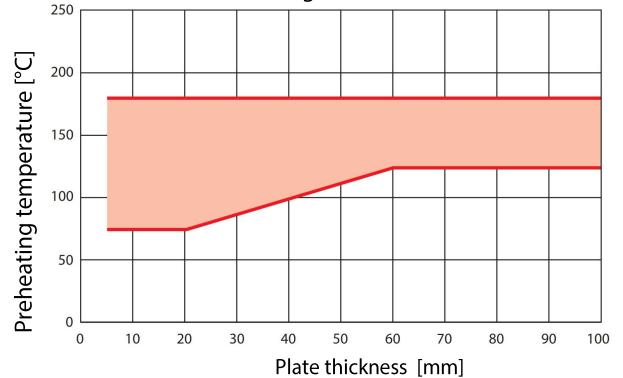

DILLIMAX 965

Gas shielded metal arc welding/ butt weld
(1.0 kJ/mm, HD 2 ml/100g)

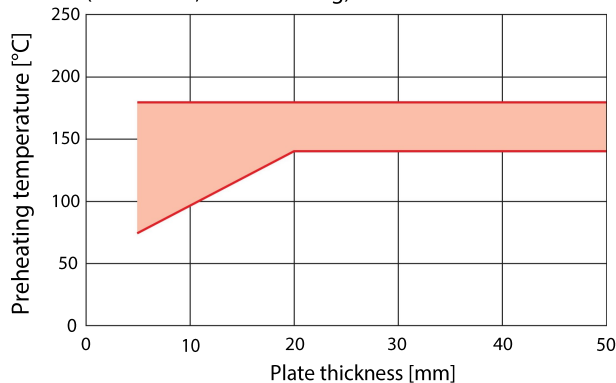

Gas shielded metal arc welding/ fillet weld
(1.5 kJ/mm, HD 2 ml/100g)

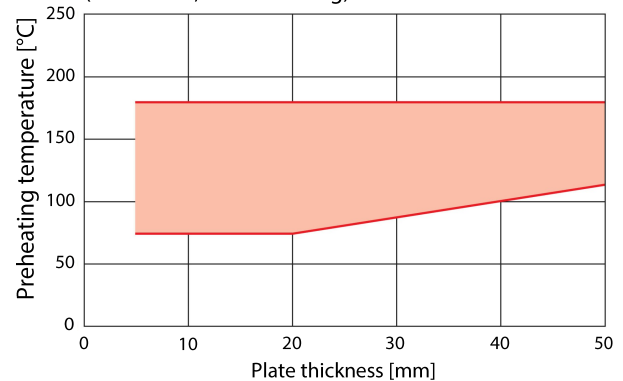

The risk of cracking occurring in welded joints as a result of residual stresses is particularly great for a seam cross section that is only partially filled. Therefore, cooling down below the prescribed interpass temperature must be avoided during the entire welding process.



Reduction of residual stresses by

- ◆ avoiding harsh cross sectional transitions and concentration of weld
- ◆ ensuring individual components fit well
- ◆ ensuring the welds are free from notches
- ◆ selecting advantageous welding sequences. The weld sequence should basically be selected to ensure individual components can shrink freely for as long as possible.

For plate thickness above 30 mm and when using welding techniques that introduce a large amount of hydrogen into the workpiece (e.g. submerged arc welding), it is advisable to carry out low hydrogen annealing at 200 °C immediately after welding. The annealing time depends on the thickness of the component and should not be shorter than two hours.



Stress relieving

DILLIMAX steels and their appropriately welded joints have a sufficient degree of toughness to be used in highly loaded components, in general without requiring a stress relieving treatment. If stress relieving is necessary due to regulations or for constructive reasons, Dillinger should be consulted.

The highest stress relieving temperature should be 40 °C below the tempering temperature of the quenching process. The holding time when annealing should not exceed 60 minutes.

If another heat treatment or longer holding time are required by the fabricator, this must be specified when ordering.

If longer holding times are prescribed, the stress relieving temperature is to be further reduced in relation to the tempering temperature. In the case of a high level of residual stresses or for very thick plates, care must be taken to avoid pronounced differences in temperature in the component while heating up to annealing temperature. Due to their chemical composition and heat treatment, DILLIMAX steels have a relatively high strength at elevated temperatures. Their stress relief during stress relieving is thus less complete than for ordinary structural steels. Stress relieving of DILLIMAX 1100 is not permissible without impairing the properties.

Filler metals and consumables

The filler metals must be selected according to the required mechanical properties. Since the weld metal may mix with the base material, root welds can be created with fillers which produce a "softer" weld metal than the associated filler and cap passes. The same applies to fillet welds which are not subjected to full load – in this case, too, it is often possible to use "softer" fillers by increasing the weld thickness.

Basic coated rod electrodes are principally used in manual arc welding for reasons of toughness. Basic coated rod electrodes possesses two outstanding properties: the impact energy of the weld metal is higher, especially at low temperatures, and the amount of hydrogen introduced is lower than with any other type of coating. Drying and storage must be carried out according to the manufacturer's instructions. With the same considerations in mind, only basic powders should be used for submerged arc welding.

The following table shows an exemplary overview of welding consumables, classified according to standard and welding process.

	Classification		
	Manual arc welding	Submerged arc welding	Gas-shielded arc welding
DILLIMAX 500	SFA/AWS A5.5 : E90* EN ISO 18275-A : E 55*	SFA/AWS A5.23 : F9* EN ISO 14171-A : S50* EN ISO 26304-A : S*	SFA/AWS A5.29 : E7*T* EN ISO 17632-A : T 42* EN ISO 16834-A : G 55 * SFA/AWS A5.28 : ER100S* SFA/AWS A5.28 : E90* SFA/AWS A5.29 : E9*T* EN ISO 18276-A : T 55* EN ISO 16834-A : G 55*
DILLIMAX 550	SFA/AWS A5.5 : E100* EN ISO 18275-A : E 62*	SFA/AWS A5.23 : EG* EN ISO 14171-A : S3* EN ISO 26304-A : S3*	EN ISO 18276-A : T 55* SFA/AWS A5.28 : ER100S* SFA/AWS A5.28 : E90* SFA/AWS A5.29 : E91* EN ISO 16834-A : G 69*
DILLIMAX 690	SFA/AWS A5.5 : E110* EN ISO 18275-A : E 69* SFA/AWS A5.5 : E110* EN ISO 18275-A : E 69*	SFA/AWS A5.23 : EG EN ISO 26304-A : S3Ni2,5CrMo EN ISO 26304-B : (SUN4C1M3)	EN ISO 18276-A : T 69* EN ISO 18276-B : T 76* EN ISO 17632-A T69* SFA/AWS A5.28 : ER110* SFA/AWS A5.36 : E111* EN ISO 16834-A G 89*
DILLIMAX 890	EN ISO 18275-A : E 89*	-	EN ISO 18276-A : T 89* SFA/AWS A5.28 ER120* (EN ISO 16834-A G 89*)
DILLIMAX 965	(EN ISO 18275-A : E 89*)	-	(EN ISO 18276-A : T 89*) (SFA/AWS A5.28 ER120*) (EN ISO 16834-A G 89*)
DILLIMAX 1100	(EN ISO 18275-A : E 89*)	-	(EN ISO 18276-A : T 89*) (SFA/AWS A5.28 ER120*)

() = welding consumable undermatching

Checklist for general improvement of welding performance

- ◆ Prepare the weld: Seam area must be metallicly bright, dry and free from flame cutting slag, rust, scale, paint and other impurities
- ◆ Use Suitable filler materials
- ◆ Minimize hydrogen input
- ◆ Observe preheating and interpass temperatures
- ◆ Select suitable line energy
- ◆ Reduce residual stresses
- ◆ Maintain the highest stress relieving temperature: It must be at least 40 °C below the tempering temperature. The holding time when annealing should not exceed 60 minutes

Disclaimer:

The information and data provided concerning the quality and/or applicability of materials and/or products constitute descriptions only. Any and all promises concerning the presence of specific properties and/or suitability for a particular application shall in all cases be deemed to require separate written agreements.

This processing information is updated at irregular intervals. The current version is relevant. The latest version is available from the mill or as download at www.dillinger.de.

Contact

AG der Dillinger Hüttenwerke

Postfach 1580

66748 Dillingen / Saar

Germany

Tel.: +49 6831 47 3452

Fax: +49 6831 47 992025

e-mail: info@dillinger.biz

You can find your contact person on www.dillinger.de

Issue 12/2022