



ADVANCED STRUCTURAL ENGINEERING STEELS

Longitudinally profiled plates (LP plates)

TAILOR-MADE STEEL

It is generally difficult to reconcile financial savings with high technical standards. Dillinger longitudinally profiled plates (LP plates) nonetheless enable modern civil engineers to achieve both simultaneously. In addition to weight reductions, plate thickness which varies along plate length also makes it possible to minimize the number of welded joints. Moreover an optimized matching of the plate profile to the theoretical stress distribution pattern also permits a safe and reliable, durable and fatigue proof design.

Dillinger supplies LP plates in all structural steels up to and including S460 (minimum yield strength 460 MPa) in either as rolled or normalized delivery condition. These tailor-made plates are available in the most diverse range of formats and assure an elegant, light weight and, above all, cost efficient solution.

A broad range

The range of LP plates available is virtually unlimited. Table 1 shows the technical feasibility and possible dimensions. Here, a “plate segment” denotes a length of plate of constant thickness or constant taper.

LP plate	Plate segment
Thickness: 20 to 150 mm	Maximum number of different segments*: 5
Maximum thickness variation: 40 mm	Maximum segment taper: 10 mm/m
Length: 4,000 to 24,000 mm	Minimum segment length: 1,000 mm
Width: 1,500 to 3,000 mm	
Maximum plate weight: 22 t	
	<i>Remark: min. thickness, thickness variation and max. length restrictions, if at least one plate segment taper is higher than 5 mm/m.</i>
*Please enquire for profiles with a larger number of segments.	

Table 1: Dimensions and feasibility

Possible profile types

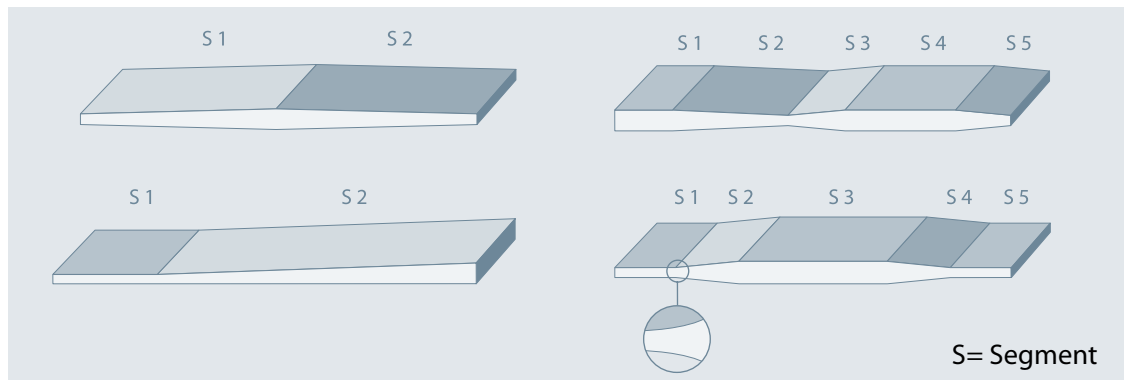
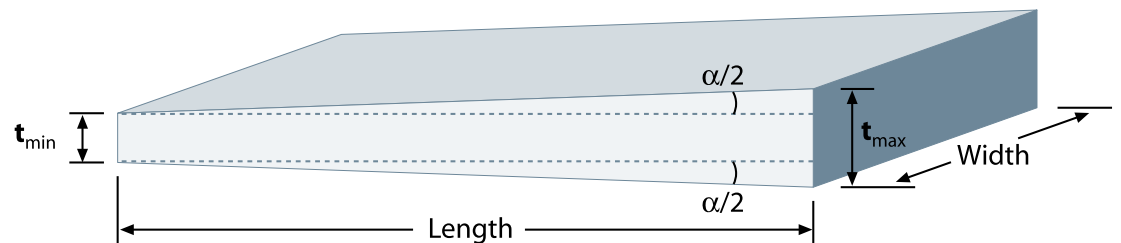

E-Service

Our E-Service platform (www.dillinger.de) includes a programme which you can use online to determine whether your profile is feasible.

We will also be pleased to provide you with advice in person.

LONGITUDINALLY PROFILED PLATES

Grade Structural steels in conformity to EN 10025-2, EN 10025-3 and EN 10025-5. Other grades possible by agreement.

Delivery condition As rolled (AR) or normalized (N).

Tolerances The conditions set out in EN 10029, which must be agreed in advance (standard: Class A thickness tolerance) apply to tolerances. The tolerance applicable to the maximum thickness of a plate applies to the plate as a whole. Dillinger reserves the right to double the maximum positive tolerance in individual cases. The customer will be informed in due time concerning this.

Examples of LP plates applications The great cost efficiency of LP plates in engineering structures is largely demonstrated by numerous reference projects throughout Europe. Welded beams, above all, can thus be advantageously fabricated with the minimum necessary input of material and with the avoidance of unnecessary welded joints. High cost effectiveness in production and high reliability in service – these are the benefits of our longitudinally profiled plates for modern structural steel engineering.

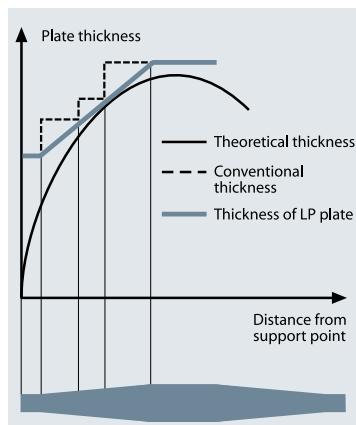

Optimized matching of thicknesses with the stress forces in the flange plates



The Larche Viaduct, France, completed in 2008; 310 t of LP plates in grades S355N/NL. Plate thickness: up to 120 mm

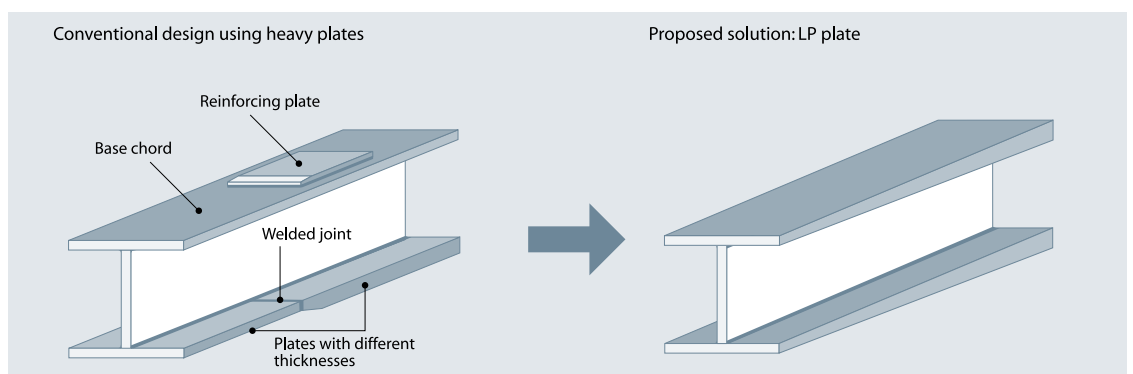

Comparison of a conventional and an LP plate beam structure

Benefits of using LP plates

Cost savings

- Lower structure weight
- Fewer welds
- Shorter processing time and lower fabrication costs
- Lower transportation and installation weight

Optimization of fatigue performance

- Optimized matching of thicknesses with the stress forces
- Relocation of welds to less stressed points
- Improved component reliability

Photos cover and reverse sides:

Moselle Bridge in Schengen, Luxembourg: 1,100 t of LP plates, grade S355N, thickness up to 140 mm



Contact

You can find your contact person on
<http://www.dillinger.de/kontakt>

DILLINGER 

AG der Dillinger Hüttenwerke
P.O. Box 1580 · 66748 Dillingen/Saar · Germany
Telephone: +49 6831 / 47 3456 · Telefax: +49 6831 / 47 3089
e-mail: info@dillinger.biz · <http://www.dillinger.de>